

NOTE:
 R151 = 2K7 FOR 12V MODULE
 R151 = 3K3 FOR 24V MODULE
 R151 = 4K7 FOR 48V MODULE

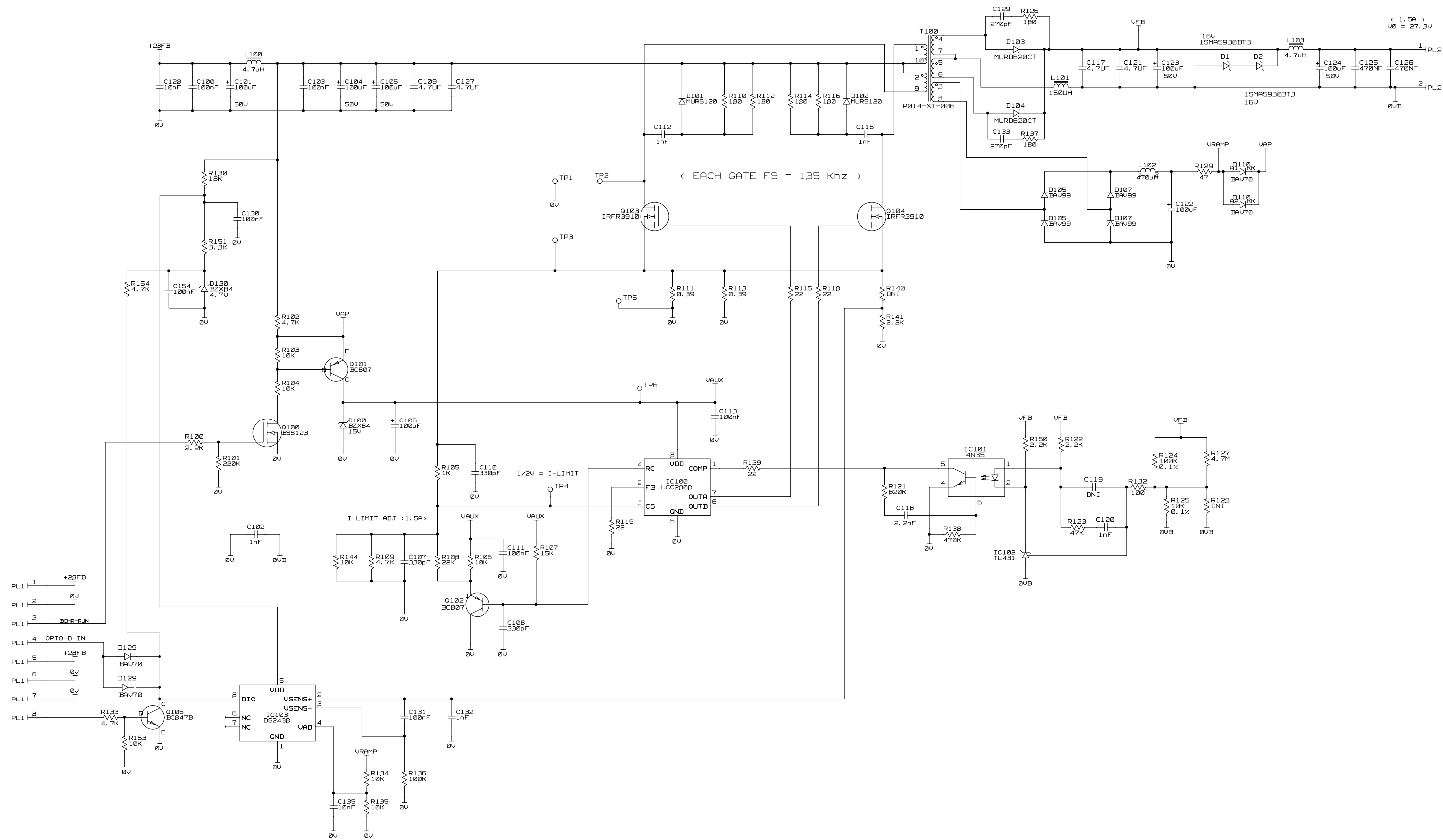

REV/ISS	AMENDMENTS	DRAWN	CHKD	D. O.	APVD	DATE
02A	ECO. 101200556	TB	RVDC	?	RVDC	27/05/05
02A	ECO. 101200152	TB	RVDC	?	RVDC	01/05/04
01C	ECO. 101200312	TB	RVDC	?	RVDC	05/02/04
01B	ECO. 101200271	TB	RVDC	?	RVDC	05/02/04
01A	24V PROTOTYPE CLONED FROM 12V	TB	RVDC	?	RVDC	10-01-03

© TAIT ELECTRONICS		A1
T8800		
PMU DC-DC 40W AUX PS 24V		
IPN: 220-02044-03	ISSUE: A	VARIANT NUMBER: ?
FILE DATE: Mon Jun 27 11:17:07 2005		
ENGINEER: R Van Der Cloff	FILE NAME: 220_02044	SHEET NUMBER: 1 OF 1